

1-053 Cylinder Quarter-Turn Pr14.1 L13.5

Key operable, Optional pre-assembly



Product Notes:

- Fasten to panel with nut
- Pre-assembled Quarter-Turn can be installed in cutout
- RH and LH application

Material:

- **Housing:** Zinc Die, Chrome Plated or Black
- **Cylinder:** Zinc Die, Chrome Plated
- **Nut and cam:** Steel, Zinc Plated

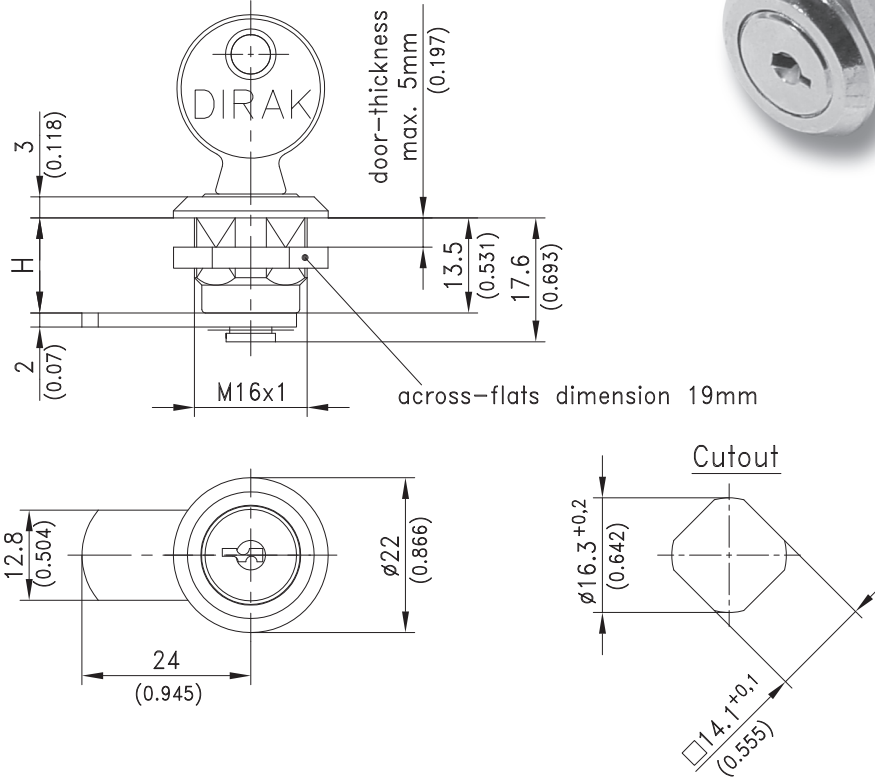
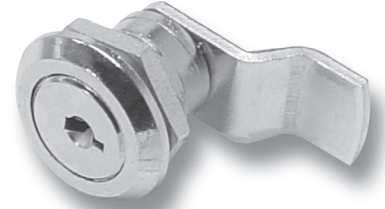

Housing Zinc Die, Chrome Plated		Nut		Grounding Nut	
Locking Type	H - mm	Standard	Special Version	Standard	Special Version
a)		Riveted Cam*	Cam with C-clip	Riveted Cam*	Cam with C-clip
Keyed alike	7.5	220-9207	220-9207.00-07200	220-9213	220-9213.00-07200
DIRAK 2233X	13.5 (drawn)	220-9208	220-9208.00-07200	220-9214	220-9214.00-07200
	19.5	220-9209	220-9209.00-07200	220-9215	220-9215.00-07200
Keyed different	7.5	220-9210	220-9210.00-07200	220-9216	220-9216.00-07200
	13.5 (drawn)	220-9211	220-9211.00-07200	220-9217	220-9217.00-07200
	19.5	220-9212	220-9212.00-07200	220-9218	220-9218.00-07200

*NOTE: The door thickness of the quarter-turns with riveted cam must not exceed 3mm

Housing Black Matt		With Nut Special Version	
a1) Locking Type	H - mm	Cam with C-clip	
Keyed alike	7.5	220-9220.00-07200	
DIRAK 2233X	13.5 (drawn)	220-9221.00-07200	
	19.5	220-9222.00-07200	
Keyed different	7.5	220-9223.00-07200	
	13.5 (drawn)	220-9224.00-07200	
	19.5	220-9225.00-07200	

b) Special cams	01.100
All locks supplied with two keys.	
c) Quarter-Turn with fastening clip, See Page	01.83